

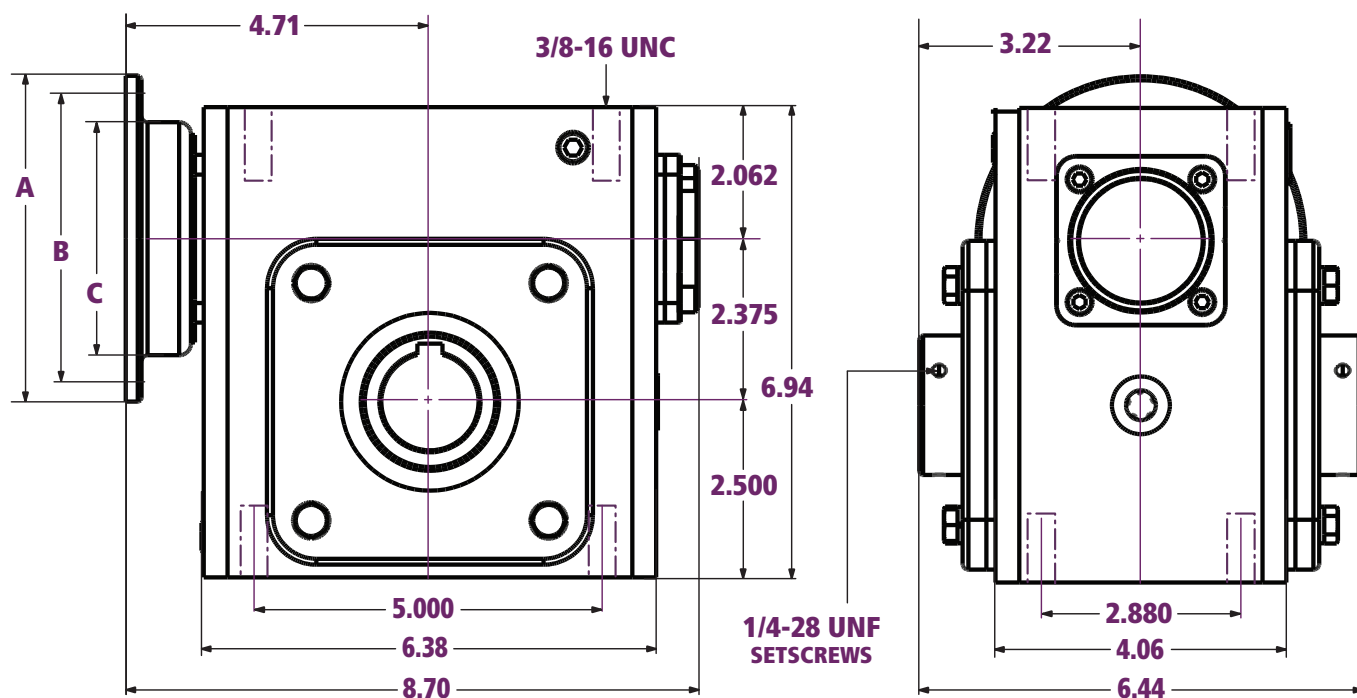

# XH237 Dimensions

All dimensions listed in inches



## Motor Options & Dimensions (in)

NEMA Frame	Motor Shaft Dia. (in)	A	B	C
		OD Flange	Bolt Circle	Pilot Bore
56C	0.625	6.50	5.88	4.5
140TC	0.875			

## Output Bushing Kits

Output Bushing Diameter (in)
5/8
3/4
7/8
1-1/8

## Output Hollow Bore

Output Keyway (in)	Output Bore (in)
3/8 x 3/16	1.250

## Ratios

Nominal Ratios	Exact Ratios
5:1	5.3:1
10:1	10.3:1
15:1	15.5:1
20:1	19.5:1
30:1	30.0:1
40:1	40.0:1
50:1	50.0:1
60:1	60.0:1

## Efficiency

Nominal Ratios	Efficiency (%)
5:1	~ 93
10:1	~ 89
15:1	~ 84
20:1	~ 82
30:1	~ 76
40:1	~ 71
50:1	~ 64
60:1	~ 61

## Specifications

Center Distance (in)	Weight (lbs)	Est. Oil Fill Amount* (oz)
2.375	37.4	22.0

\*For Position 1.

# XH237 Accessories

## and X237 Base Kit Dimensions

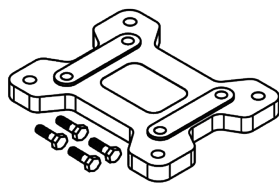
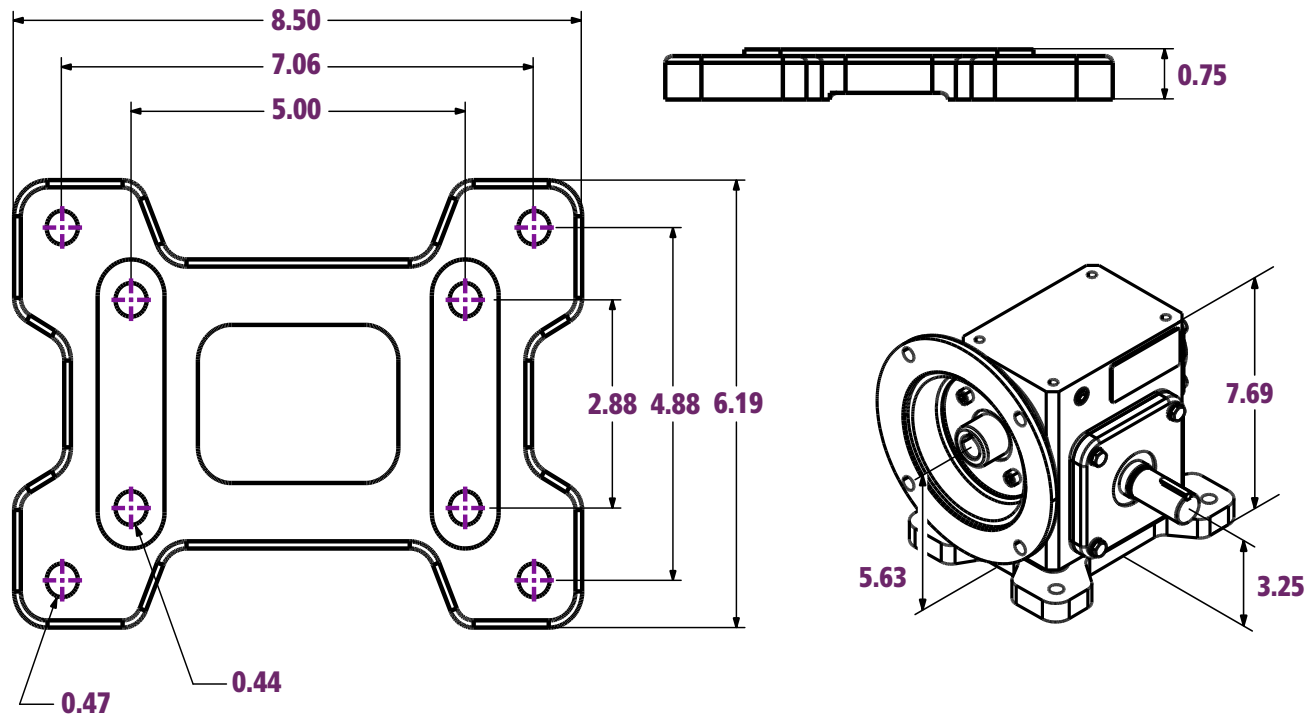

**Foot Mounted Base Kit**

XBK237

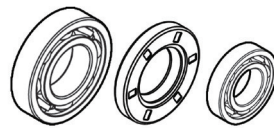

**Component Repair Kit**

XHRK237

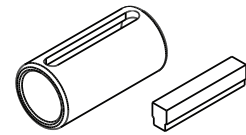

**Input Quill Adapter Option**

X143-56

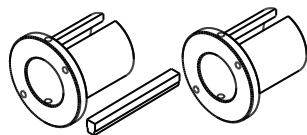

**Output Bushing Kits\***

VH237  
(See other page for bore sizes)

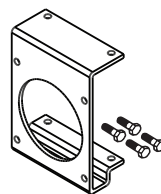

**Output Bracket Kit\***

XOB237

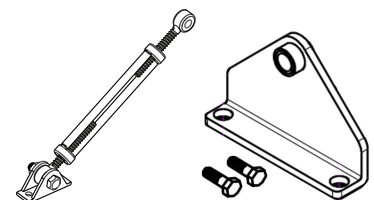

**Torque Arm Kit\***

XTA237

\*Made to order.